

X5



5.085 - 5.100 - 5.110 - 5.120



NEW X5, VERSATILITY HAS NEVER BEEN SO COMFORTABLE

Building on its extensive experience in technology innovation, McCormick has developed the next-generation X5 series, a new range of utility tractors that will surprise farmers with performance, versatility and comfort comparable to higher-class models.

The new McCormick X5 is a truly versatile utility tractor. Ideal for open-field tasks like ploughing, tilling and harrowing, this handy tractor is equally perfect for sowing and haymaking as well as for livestock farming and transport applications. Designed to handle a wide variety of tasks with maximum efficiency, the X5 tractor will also offer superior automotive-style comfort.

Designed with versatility in mind, the new X5 can be tailored to meet the specific needs of each farmer. Tractor key features include:

- An iso-mounted four-post cab with all-round visibility and automotive-grade fit and finish for maximum comfort of operation. All controls are ergonomically arranged and a new multifunction controller provides easy and precise control of all tractor and implement functions including the front loader and the Hi-Lo and HML transmissions. In addition, the new SmartPilot joystick, available with the P3-Drive transmission, provides user-friendly control of the main functions of the tractor such as the transmission, the reverse power shuttle, the rear hitch and the front and rear PTOs. The low-profile roof allows for easy access to low-ceiling barns and stables, while the transparent roof hatch

provides extra visibility for front loader operation.

- A new steering system – the ADS+ Advanced Driving System – designed to enhance driving comfort and working efficiency, thereby increasing productivity.
- New FPT 3.4L and 3.6L engines meeting Stage V/Tier 4 Final emissions regulations with powers up to 114 hp.
- A variety of configurable transmissions ranging from the Speed Four transmission with 12 FWD+12 REV speeds to the XtraShift P3-Drive transmission with HML powershift providing up to 48 FWD and 16 REV speeds. Each version features a reverse power shuttle (RPS) with modulation control and a creep speed unit.
- A hydraulic system with triple pump providing a total flow of 82 l/min for efficient operation of all hydraulic functions and of up to six remote valves.
- Available: front hitch and PTO and McCormick M20 front loader.
- Available: satellite-based guidance system for maximum working accuracy; ISObus system for simple and efficient implement control, including in automatic mode; Fleet & Remote Diagnostics Management system for remotely monitoring the activities of the tractor fleet and analysing the working data; McCormick Farm system, an innovative Farm Management Information System (FMIS) that manages prescription maps and simplifies the administration of the farm.

Efficient, comfortable and versatile, the McCormick X5 is a great companion you can rely on, always.

HIGHLIGHTS

Cab

- › Total View Slim cab: all-round visibility and maximum operating comfort
- › Mechanical cab suspension system
- › Driver's seat with air-suspension system
- › Ergonomic controls and automotive-grade fit and finish
- › 8.4-inch touch screen monitor for satellite guidance and ISObus control
- › Low-profile roof for easy access to low-ceiling barns and stables

Engine

- › X5 range: FPT F36 3.6L engine delivering up to 114 hp
- › X5-085 model: FPT F34 3.4L engine delivering 75 hp
- › Engines meeting Stage V/Tier 4 Final emissions regulations

- › X5 range: 135L fuel tank and 13L AdBlue tank
- › X5.085 model: 103L fuel tank, without AdBlue

Transmission

- › Speed Four transmission: 12 FWD + 12 REV speeds; 16 FWD + 16 REV speeds with creeper
- › Power Four transmission with two-stage Hi-Lo powershift: 24 FWD + 24 REV speeds; 32 FWD + 32 REV with creeper
- › XtraShift transmission with three-stage HML powershift: 36 FWD + 12 REV speeds; 48 FWD + 16 REV speeds with creeper
- › XtraShift transmission with three-stage HML powershift and P3-Drive: 36 FWD + 12 REV speeds; 48 FWD + 16 REV speeds with creeper

Axles

- › Suspended front axle with brakes, full locking differential and electro-hydraulically operated four-wheel drive

Hydraulic system

- › Open-centre hydraulic system with up to 82 l/min flow rate
- › Electronic rear hitch with up to 4500 kg lift capacity
- › Front hitch and PTO for maximum versatility

Digital Solutions

- › ISObus system and Precision Steering Management
- › McCormick Fleet & Remote Diagnostics Management

DIGITAL SOLUTIONS

Precision - High performance
page 37

CAB

Comfort - Visibility
page 8

FRONT LOADER

Efficiency - Productivity
page 34

ENGINE

Powers - Consumptions
page 14



TRACTION

Front axle
page 20

HYDRAULIC SYSTEM

PTOs - Rear & front hitches - Remotes
page 23

TRANSMISSION

Speed Four / Power Four
page 16

FRONT AND REAR HITCH

Strength - Functionality
page 26





MAKE YOURSELF COMFORTABLE, THE **X5** TAKES CARE OF THE REST

McCormick X5: productivity in plain view.

The four-post structure of the Total View Slim cab is designed to offer excellent panoramic view and good close-range visibility making manoeuvring in tight spaces easier and safer. The tractor can be equipped with up to ten LED work lights. Six adjustable work lights are positioned on the cab roof to ensure optimum illumination of the work area at night. A transparent roof hatch provides extra visibility for loader operation.

Total View Slim cab: a comfortable working environment makes a difference.

The Total View Slim cab puts the focus on operator comfort: a spacious workspace with flat floor and automotive-grade fit and finish, a comfortable air-suspended seat, a tilt-adjustable steering wheel, ergonomically-arranged intuitive controls, a multi-function controller, a highly-efficient automatic climate control, DAB+ radio and many other creature comforts make long working days in the field less tiring. Because the McCormick **X5** does not compromise on comfort.

The X5 reduces fatigue and improves your well-being.

Featuring silent-block suspension units at the front and shock absorbers with up to 96 mm travel at the rear,, the cab of the **X5** is equipped with our exclusive Panhard rod that absorbs the shocks and vibrations generated by uneven ground, thereby creating a comfortable working environment that enhances productivity. The new sound deadening system also reduces in-cab noise ensuring a quiet workplace.

TOTAL VIEW SLIM CAB, COMFORT AND ALL-ROUND VISIBILITY

Spacious, quiet, technically innovative and above all comfortable – that's the new Total View Slim cab of the McCormick X5. The new cab offers the comfort of two silent-block suspension units at the front and two shock absorbing rubber mounts at the rear for a unique driving experience. This solution cuts down vibrations caused by rough terrain, making for more relaxing and productive work days. Also, a new sound proofing system ensures the cab is completely isolated from exterior noise.

Every detail within the Total View Slim cab has been designed with operator comfort in mind: spacious interior, automotive-grade fit and finish, flat floor, air-suspended seat, tilt-adjustable telescopic steering wheel tilting with the instrument panel, efficient ADS+ steering system, easy-to-use ergonomic controls, new SmartPilot joystick to control the main tractor functions, high-performance climate control system, DAB+ radio and plenty of other creature comforts make your work days in the field more pleasant and relaxing.

With its four-post design and its large glass panels, the Total View Slim cab provides an excellent all-round view and good close-range visibility, making for safe and easy manoeuvring in tight spots and at headlands. Up to ten high-contrast LED work lights, six of which fitted on the cab roof, ensure daylight illumination during night-time operation, while the transparent roof hatch provides extra visibility for loader work. With the X5, long working days in the field are less tiring and more productive.





Cab Suspension

Suspended front axle, air-suspension seat, iso-mounted cab: comfort is key in the X5 tractor range. The Total View Slim cab is mounted on two silent blocks at the front and two shock absorbers with Panhard rod at the rear with a travel of up to 96 mm. These suspension units absorb impacts and vibrations from rough terrain, while an all-new sound insulation system minimizes in-cab noise levels, creating a protected work environment that reduces operator fatigue and increases productivity.

HIGHLIGHTS

- › Iso-mounted cab: reduced vibrations and noise for maximum operating comfort
- › User-friendly ergonomic controls
- › SmartPilot joystick for control of the P3-Drive transmission and of main tractor functions
- › Adjustable steering wheel tilting with instrument panel
- › ADS+ steering system: superior comfort and satellite-based guidance
- › Efficient climate control integrated into the cab roof
- › FOPS-certified roof to protect operator from falling objects
- › Opening transparent roof hatch for front loader operation
- › Up to 10 LED work lights for proper lighting during night work

ADS+ steering system, the evolution of comfort and efficiency

The new ADS+ Advanced Driving System is a state-of-the-art electrohydraulic steering system that boosts the tractor performance, increasing comfort, efficiency and productivity. The ADS+ system:

- Corrects automatically unwanted tractor movements caused by terrain irregularities for a superior level of comfort.
- Realigns automatically the tractor's wheels in the direction of travel for a car-like driving experience.

Easy access to driving position

The access to the driving position has never been so easy, the rear-hinged doors are large and the access steps are wide and comfortable to climb. Convenient handholds fitted to the cab posts and to the doors allow operators to safely climb up and down the tractor.



LED WORK LIGHTS

The tractor is fitted with up to ten high-brightness LED work lights that provide a 360-degree illumination of the work area during night work. Six adjustable work lights are located on the cab roof.



CLIMATE CONTROL AND TRANSPARENT ROOF HATCH

Integrated into the cab roof, the climate control system creates a comfortable working environment whatever the outdoor weather conditions. The opening transparent roof hatch favours ventilation and provides extra visibility, making front loader operations easier and faster. The cab roof is FOPS certified to protect operators from falling objects during front loader operations.



DAB+ RADIO AND BLUETOOTH

The cab is fitted with a DAB+ radio with Bluetooth. Music can also be listened to via an MP3 player, an AUX connector or a USB flash drive, while an integrated microphone enables the driver to make hands-free phone calls.

- Adjusts the rigidity of the steering wheel improving stability during transport operations.
- Is prepared for the Precision Steering Management (PSM) system.
- Halves the number of rotations of the steering wheel to make a complete turn thanks to the EazySteer feature.

ROPS Version

The ROPS version of the X5 with its platform mounted on silent blocks to reduce vibration and its easily-accessible driving position with ergonomically-arranged, intuitive controls offers the operator a functional and comfortable work environment. This model also features a folding ROPS with a detachable sunroof.



MORE EFFICIENCY, MORE ECONOMY, MORE VISIBILITY – **THE X5 IS MORE**

The X5 evolves under the banner of efficiency and environmental sustainability.

The X5 tractors are powered by new FPT F36, 3.6L turbo intercooled engines with common rail injection system that deliver up to 114 hp. Powerful and responsive, these engines provide high torque values at low rpm ensuring constant performance and efficiency in any situation. Equipped with exhaust after-treatment technologies that meet Stage V/Tier 4 Final emissions, the new X5 is more eco-friendly than its predecessor.

The X5 reduces fuel consumption and improves operator comfort.

The fuel tank capacity of the new X5 tractor range has been increased to 135 litres to ensure extended operation without refuelling. The common rail injection system delivers a precisely measured amount of fuel to the engine, thereby improving performance while ensuring up to 10 percent fuel saving. Fuel efficiency is further enhanced with the Engine Memo Switch, which stores and recalls the ideal engine speed for the job at hand. This feature makes work easier and reduces operator fatigue.

The new Stage V after-treatment system does not hinder visibility.

Thanks to relocating the NOx reduction SCR system under the bonnet, the right cab post is now uncluttered, allowing full visibility during work.





FPT F36 ENGINES FOR ULTIMATE EFFICIENCY

The new **X5** tractors are powered by FPT F36 3.6L, 16-valve, four-cylinder turbo engines with intercooler and common rail injection system. The three models in the range deliver 95, 102 and 114 hp and meet the Stage V/Tier 4 Final emissions regulations using DOC, DPF and SCR after-treatment technologies. The engine/transmission matching has been redesigned enabling McCormick engineers to move the exhaust after-treatment system from the right cab post to under the bonnet for enhanced operator visibility during work.

The after-treatment system does not hinder visibility

The DOC, DPF and SCR technologies that enable the **X5** tractor to comply with the Stage V/Tier 4 Final emissions regulations are conveniently tucked away under the bonnet, so they do not interfere with the operator's view during work.



Enhanced performance and reduced fuel consumption

The engines that power the **X5** tractors are equipped with an electronically controlled injection system that injects the fuel into the engine at very high pressures, thereby enhancing performance while reducing fuel consumption. Fuel efficiency is further improved with the Engine Memo Switch, a device that stores and recalls the engine speed best suited to the job in hand. The **X5** tractor is equipped with a new 135-litre fuel tank allowing extended periods of operation without refuelling.





WITH THE X5, YOU REALLY HAVE AN EXTRA GEAR

You choose how to customise your transmission according to your needs.

The X5 tractor has proven to be a true champion of versatility. Its transmission can be fully customised to meet the user's application requirements by choosing from a variety of options: number of gear ranges, two- or three-speed powershift, creeper, synchro or power shuttle with modulation control, manual or power-assisted gearbox. The X5 offers a choice of eight transmission configurations to better meet the specific requirements of each farm.

The efficiency of transmission is tested in the field.

Used in a wide variety of applications, the transmission of the X5 is highly appreciated among farmers for its rugged construction and field-proven reliability. With McCormick transmissions, you can work with peace of mind and be sure that you'll never experience a power loss.

A transmission that improves performance and fuel economy.

The X5 can be equipped with either a two- or three-speed powershift transmission which automatically selects the most appropriate gear for the job. This prevents the engine from losing power and contributes to reducing the tractor's fuel consumption, thereby eliminating fuel waste.

With the X5, you choose the transmission that best suits your needs

Designed with versatility in mind, the X5 multi-utility tractor offers a variety of transmission configurations, all with RPS hydraulic power shuttle, to suit the specific requirements of each farm:

- 1. Speed Four:** 12 FWD + 12 REV speeds; 16 FWD + 16 REV speeds with creeper.
- 2. Power Four with Hi-Lo:** 24 FWD + 24 REV speeds; 32 FWD + 32 REV speeds with creeper.
- 3. XtraShift with HML:** 36 FWD + 12 REV speeds; 48 FWD + 16 REV speeds with creeper.
- 4. XtraShift with HML and P3-Drive:** 36 FWD + 12 REV speeds; 48 FWD + 16 REV speeds with creeper.

McCormick has further improved its renowned range of rugged and reliable transmissions to maximize the tractor's performance in terms of power and fuel efficiency.





Speed Four transmission: clean design for simple operation

The Speed Four transmission with left-hand steering-column hydraulic reverse power shuttle (RPS) offers four synchronized gears and three mechanical ranges providing 12 forward and 12 reverse speeds. With additional creeper speeds, this transmission provides a total of 16 forward and 16 reverse gears with speeds as low as 360 m/h.

Power Four electrohydraulic transmission for total reliability

The Power Four transmission with electrohydraulic Hi-Lo doubles the number of speeds to 24 forward and 24 in reverse. The creep speed option further increases the number of available speeds to 32 forward and 32 in reverse. The Power Four transmission features a hydraulic reverse power shuttle (RPS) with control lever adjacent to the steering wheel. The power shuttle version features a de-clutch button that allows the operator to shift the synchronized gears without using the clutch pedal.

XtraShift electrohydraulic transmission for ultimate efficiency

The XtraShift electrohydraulic HML transmission is a three-speed powershift that triples the gears of the Speed Four transmission providing 36 speeds forward and 12 in reverse. Combined with a creeper unit, this transmission option provides 48/16 speeds ensuring a minimum advance speed of 310 m/h. The de-clutch button and the RPS power shuttle will allow the operator to shift through all gears and change from forward to reverse without depressing the clutch pedal. The shuttle response is electronically modulated and adjustable by the operator.



PARK LOCK TO OPTIMISE SAFETY

The X5 in power shuttle configuration can be optionally equipped with Park Lock, a mechanical device which locks the transmission for added safety when parking the tractor on steep inclines.



MORE COMFORT AND PRODUCTIVITY WITH THE P3-DRIVE TRANSMISSION

The P3-Drive transmission with robotised gear shifting and three-stage HML powershift offers 12 speeds in each range which are selected automatically with the Auto PowerShift (APS) facility. In addition, the new Stop&Action function allows stopping and restarting the tractor with a simple press and release of the brake pedal. The robotised P3-Drive transmission:

- > **Improves comfort:** The P3-Drive is controlled intuitively from the SmartPilot multifunction joystick and from the fully redesigned right-hand console for superior operating comfort.
- > **Increases productivity:** The P3-Drive transmission allows choosing between the simplicity of the manual mode, which enables the driver to change gears with just two buttons, and the convenience of the automatic mode, which automatically selects the right gear. This allows the operator to fully concentrate on the task at hand for enhanced productivity.

NEW SUSPENDED AXLE FOR COMFORTABLE OPERATION

Sturdy and agile, McCormick axles are designed to ensure reliability and stability in all field and transport conditions. The new suspended axle of the **X5** tractor reduces shocks and vibrations caused by rough terrain, providing a superior level of comfort that will improve operator concentration and well-being.

Due to its rugged construction, the suspended front axle of the **X5** is perfect for front loader and front-mounted implement work. Also, due to its high ground clearance and its 55-degree steering angle, the **X5** tractor is incredibly manoeuvrable. And with the hydrostatic drive, steering is smooth and easy even at low engine rpm. The McCormick **X5** knows how to turn your work into pleasure.

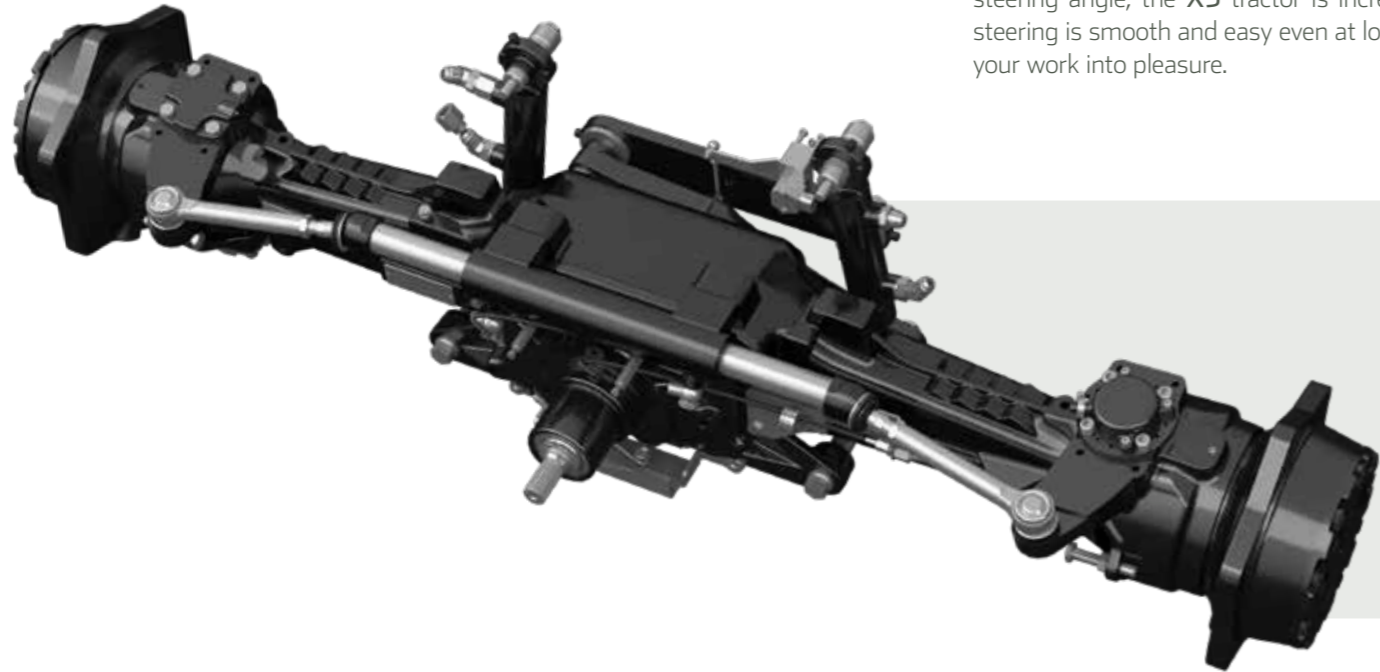

IBS BRAKING SYSTEM FOR SAFE OPERATION

Designed to ensure maximum safety on the road, the **X5** features the IBS integrated brake system. With wet disc brakes fully integrated into the front axle, the IBS system provides efficient braking on all four wheels reducing stopping distances by up to 50% as compared to two-wheel braking systems. When activated, the front and rear brakes produce a braking force proportional to the foot pressure applied on the brake pedal, thereby ensuring safe, controlled stopping power in any situation. The IBS system can be integrated with the trailer brake system to ensure efficient braking of the tractor-trailer combination for safe stopping on steep slopes.



TWIN LOCK, THE FULL LOCKING DIFFERENTIAL

The **X5** tractor range is equipped with combined front and rear differential locks to reduce wheel slip and maximize traction on all four wheels. The system automatically engages or disengages the differential lock and the four-wheel drive, making the operator's job easier and faster.





TRUE HYDRAULIC VERSATILITY TO SUIT YOUR NEEDS

The hydraulic system is configured to suit your application needs.

The hydraulic system of the X5 is configured to fit the specific requirements of each farmer. The X5's dual-pump hydraulic circuit is available in two configurations: 62 + 32 l/min or 82 + 32 l/min. The system ensures efficient management of up to seven hydraulic functions: three mechanical and one electronic rear-mounted remotes, two mid-mounted remotes and a two-way flow divider that allows simultaneous operation of two hydraulic functions. Conveniently placed high-quality quick-connect couplings provide reliable and fast connections.

High-flow hydraulics for greater operating comfort.

The high hydraulic flow of the X5 allows the tractor to operate efficiently at lower engine rpm. This reduces fuel consumption and mitigates vibrations and noise for maximum ride comfort. The dedicated steering pump ensures smooth and accurate manoeuvres whatever the operating conditions and the task at hand, further increasing operator comfort.

Improved efficiency means greater productivity.

Designed to offer true versatility, the X5 can be equipped simultaneously with a front hitch and PTO, a front loader and a rear hitch. This flexibility allows the tractor to work with front and rear implement combinations, making it a true champion of efficiency and productivity.

HIGHLIGHTS

- › True versatility with the front hitch and PTO
- › Triple pump providing 82 + 32 l/min
- › Up to seven hydraulic functions: six remote valves and one flow divider
- › Front hitch Category 2 capable of lifting up to 2200 kg.

A HYDRAULIC SYSTEM DESIGNED FOR PRODUCTIVITY AND COMFORT



The X5 features an open-centre hydraulic system with either a dual pump that provides a flow rate of 62 l/min or a triple pump with up to 82 l/min to operate the remote valves, the front and rear hitches and the front loader. A second pump with a flow rate of 32 l/min is dedicated to the steering system. This high hydraulic capacity allows the operator to:

- > speed up work;
- > carry out multiple tasks simultaneously;
- > perform heavier-duty tasks;
- > reduce fuel consumption as the engine works at lower rpm for the same flow rate;
- > experience higher levels of comfort and well-being, because the lower engine speed reduces noise and vibrations;
- > turn smoothly, even when performing the most demanding of tasks, thanks to the dedicated steering pump.

CONFIGURABLE HYDRAULIC SYSTEM FOR MAXIMUM EFFICIENCY AND FLEXIBILITY

The hydraulic system of the X5 operates up to seven hydraulic functions: three mechanical and one electronic rear-mounted remotes, two mid-mounted remotes for the use of a front loader and other front-mounted implements, and a two-way flow divider that splits one remote into two. Four types of remote valves are available that can be used in combination to suit different application needs:

- **Standard:** double-acting;
- **Kick-out:** with automatic detent release;
- **Float:** for implements that follow the contour of the ground;
- **Hydraulic motor/float:** for implements requiring a hydraulic motor or a float function.

The X5 multi-purpose tractor is a champion of versatility and efficiency: each configuration allows the tractor to work with the front hitch, the front loader, the rear hitch and a variety of front- and rear-mounted implements. Each remote features high-quality, easy-to-reach quick-release couplings for fast operation. Also, the flow divider allows the user to adjust the oil flow delivered to each remote.



WIDE CHOICE OF REAR HITCHES TO MEET EVERY NEED



The **X5** tractor can be equipped with three types of rear hitch to suit different application needs:

- > Mechanical: simple and easy to use;
- > Mechanical with ELS system: speeds up headland operations;
- > Electronic: repeats operations and recalls stored positions with maximum precision for greater productivity.

Each option features external hitch controls on fenders. Quick-attach couplings allow for convenient and fast connection and disconnection of implements. The three-point hitch Category 2 can be equipped with twin assistor rams, boosting lift capacity up to 4500 kg.

Mechanical rear hitch and Ergonomic Lift System

The mechanically-operated rear hydraulic hitch of the **X5** is easy to use and guarantees precise implement operation. The rear hitch can be optionally equipped with the Ergonomic Lift System (ELS), which raises and lowers the implement with the simple click of a button. The ELS system speeds up headland turns, thereby reducing working time and increasing productivity.

Electronic rear hitch

The rear hitch can be equipped with electronic lower link draft sensing for precise implement control and efficient operation. The electronic hitch control raises and lowers the implement automatically making headland turns easier and faster. In addition, the Auto PTO feature will automatically disengage and reengage the PTO during headland operations for enhanced productivity. The electronic hitch of the **X5** also features a dampening function, which is activated by a simple button push, that reduces bounce when travelling on the road with raised implements.

Automatically operated one- or four-speed PTO

The **X5** is equipped with a rear 540-rpm PTO. A four-speed PTO providing 540/540E/1000/1000E rpm is also available as an option. A hydraulically-operated wet-disc clutch enables smooth and modulated engagement of the PTO, ensuring a soft start-up of the implement. External PTO controls located on the rear fenders make it easier to attach implements from the ground.

Front hitch and front PTO

A front hitch and a front PTO are available as an option for applications using front-mounted implements and rear and front implement combinations, further enhancing the versatility of the **X5** tractor range. Offering a maximum lift capacity of 2200 kg, the front hitch Category 2 features raise/lower and float control functions. The PTO with wet multi-disc clutch has a speed of 1000 rpm and is electro-hydraulically operated. The PTO has both in-cab and external controls making implement attachment quick, easy and convenient.



McCORMICK X5.085: THE ULTIMATE UTILITY TRACTOR

Unmatched in economy.

The McCormick **X5.085** is the ultimate utility tractor for economy, efficiency and versatility. A truly smart tractor, with its 75 hp the **X5** meets Stage V/Tier4 Final emissions regulations using a urea-free after-treatment system. This solution reduces tasks and maintenance resulting in significant time and money savings for farmers.

Unmatched in efficiency.

The **X5.085** is amazing! With its 3.4-litre engine, this champion of efficiency knows how to fully exploit the 75 hp hidden under the bonnet. With up to 56 percent torque backup, the **X5.085** boasts the highest torque rise on the market and provides exceptional pulling capacity and outstanding agility to handle tough conditions and heavy loads. The transmission of the **X5.085** can be fitted with a three-stage HML powershift. The tractor features 34-inch tyres for improved ground clearance and can be further equipped with up to eight LED work lights for optimum visibility during night work.

Unmatched in versatility.

Designed with versatility in mind, the **X5.085** is unique of its kind, since it combines the strength of utility tractors with the agility of lightweight vehicles. Its great efficiency makes the **X5.085** the ideal tractor for soil preparation activities, while its excellent weight-to-power ratio makes it extremely nimble on slopes and on the road. Compact and responsive, the **X5.085** is equally perfect for barn and stable work.





TOP-CLASS PERFORMANCE AT **LOW COST**



The **X5.085** gives you the performance of a higher-class tractor, as it seems to have some 10 hp in excess of its 75 hp rating. The tractor is powered by an FPT F34 3.4L four-cylinder turbo engine with multivalve technology, intercooler and electronic common rail injection system. With a torque of 375 Nm at 1400 rpm and 56 percent torque backup, this engine maintains a constant power output between 1400 and 2200 rpm. The fuel tank capacity has been increased to 103 litres, allowing the tractor to run for many hours of continuous operation without the need to refuel.

Equipped with DOC and DPF technologies, this 75-hp smart utility tractor meets the Stage V/Tier4 Final emission regulations without using a urea-based after-treatment system. This results in significant operating cost savings for farmers.

RUGGED AND STABLE **FRONT AXLE** FOR RELIABILITY IN ANY SITUATION

The **X5.085** tractor features a compact, rigid-mounted front axle that further enhances the tractor's agility. Designed for ruggedness and stability, the front axle of the **X5.085** provides reliable performance in any situation, from front loader operations to transport applications. With its high ground clearance and its 55-degree steering angle, this tractor provides excellent manoeuvrability in confined spaces.



A HYDRAULIC SYSTEM TAILORED TO YOUR NEEDS

The **X5.085** features an open-centre hydraulic system with two pumps, one provides a flow rate of 56 l/min to operate the remote valves, the other supplies 32 l/min to the steering system. The hydraulic system of the **X5.085** operates up to six hydraulic functions: five rear and two mid-mounted remote valves, and a two-way flow divider that splits one remote into two.

The **X5.085** offers four different types of remote valves to suit different application needs:

- > **Standard:** double-acting;
- > **Kick-out:** with automatic detent release;
- > **Float:** for implements that follow the contour of the ground;
- > **Hydraulic motor/float:** for implements requiring a hydraulic motor or a float function.

To enhance the tractor versatility, the user can choose the number and type of remote valves that are best suited for each application. Easy-to-access quick-release couplings ensure fast connections for improved efficiency.



Functional and rugged hitches for precise operation

The **X5.085** tractor features a user-friendly mechanically-operated rear hitch that guarantees precise implement control. The tractor can be optionally equipped with the Ergonomic Lift System (ELS), which automatically raises and lowers the implement with the simple click of a button, making headland turns easier and quicker. This reduces working time, thereby improving productivity. Hitch controls are located both inside the cab and on the rear fenders for easier implement connection. The rear hitch features a Category 2 three-point linkage that provides a maximum lift capacity of 3900 kg. The Category 2 front hitch is capable of lifting 1700 kg.

The **X5.085** can be equipped with an electronically-controlled rear hitch that provides a number of useful features: draft sensing on the lower link for precise implement control; automatic raise/lower for easier and faster headland turns; Auto PTO function to automatically engage or disengage the PTO for enhanced tractor performance and productivity; hitch dampening system to absorb shocks and vibrations during transport for maximum ride comfort.



McCORMICK TRACTOR AND FRONT LOADER: THE PERFECT DUO



McCormick is committed to constantly improving the performance of its equipment. True to its tradition of efficiency and productivity, McCormick has developed two rugged front loaders: the M20, designed to match the X5 tractor range, and the M15, specifically built for the X5.085 model. Both front loaders offer a variety of convenient features:

1. The new ergonomic joystick allows the operator to easily control a number of functions like raise/lower, load/unload, 3rd and 4th function, and transmission.
2. To avoid crop damage, the loader frame does not reduce the tractor's ground clearance;
3. The front loader does not limit the tractor's turning radius.
4. A suspension with two pressure accumulators ensures smooth loader operation.
5. The loader's rigid hydraulic lines reduce oil overheating and simplify maintenance operations.



6. The roof hatch of the tractor cab allows better visibility during front loader work.
7. The front loader can be used even when the tractor is equipped with a front-mounted hitch.
8. The X5 is equipped with special supports designed to make fitting and removal of the front loader easier. The Euro implement carrier allows a wide range of implements to be fitted.
9. The bucket level gauge allows the operator to determine the exact angle of the implement to the ground.
10. Constructed from HLE steel, the McCormick front loaders offer a high lift capacity: 1800 kg for the M20 and 1500 kg for the M15.

McCormick tractors and front loaders form together a perfect duo that will deliver best-in-class efficiency and productivity in any application.





X5 HC, GRADUATED IN HORTICULTURE



Designed for best-in-class comfort and productivity, the **X5 HC** tractor is a true horticulture specialist. Ideal for planting, fertilizing, irrigating and harvesting vegetables, fruits, corn, rice and other crops, this tractor features large-diameter equal-sized wheels with narrow tyres that provide a ground clearance of up to 700 mm. Such a high ground clearance is designed to protect delicate crops reducing potential contact damage to a minimum. The **X5 HC** also provides minimal soil compaction and with its tight turning radius makes manoeuvring on headlands easier than ever. The tractor's narrow tyres are type-approved for road transport. The **X5 HC** tractors are powered by FPT 3.6-litre, 16-valve, four-cylinder turbo engines with intercooler and common rail injection system that meet the Stage V/Tier 4 Final emissions regulations and deliver up to 102 hp. The Power Four Hi-Lo transmission provides 24 forward and 24 reverse speeds. The creeper increases speeds to 32 forward and 32 in reverse. The steering-column shuttle lever and the de-clutch button allow clutchless gear shifting. The open-centre hydraulic system features a double pump that provides 62 + 32 l/min. The Total View Slim cab offers excellent all-round visibility and optimum comfort: ample space, flat floor, air-suspended driver's seat, fully adjustable steering wheel, ergonomic controls, automotive-grade fit and finish and climate control. Up to ten LED work lights ensure proper illumination during night work.

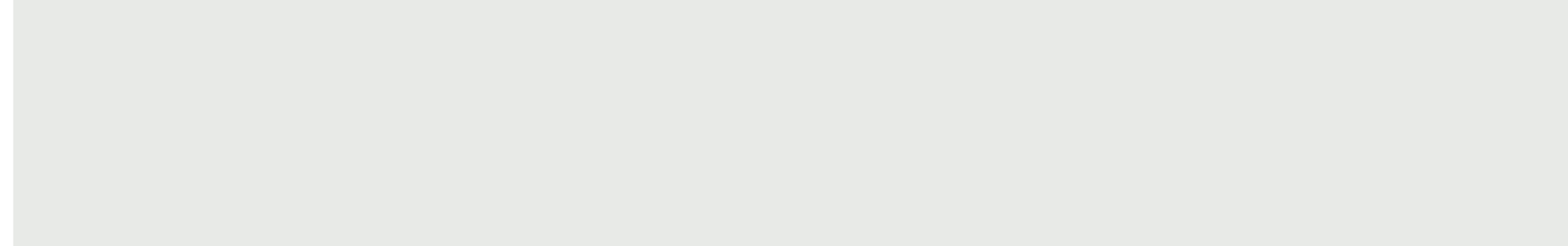

McCORMICK DIGITAL SOLUTIONS BRING THE FUTURE TO THE FIELD

Technological innovation improves working conditions, increases productivity and protects the environment. Following this philosophy, the Argo Tractors Group has prepared its tractors for the most cutting-edge digital and telematic technologies. This will help farmers manage their machinery fleets and their farms more efficiently and remotely, wherever they are. **McCormick Digital Solutions** offers a range of advanced functionalities:

Telemetry and Remote Diagnostics: Thanks to the Fleet & Remote Diagnostics Management system, telemetry monitors your fleet analysing tractor performance data, while remote diagnostics enables tractor parameters to be monitored and managed from a remote location.

Precision Farming: The Precision Steering Management satellite guidance system improves working accuracy and efficiency; the ISObus system allows optimum control of AEF-certified compatible implements.

Farm Management: McCormick Farm manages prescription maps and simplifies farm management.

Digital Services: The My McCormick app provides easy access to the McCormick world.

Cloud Data: The Agrirouter cloud platform allows integrated communication among all services.

McCormick Digital Solutions give you more performance, more efficiency and more profitability while improving simplicity, safety and comfort.





FLEET & REMOTE DIAGNOSTICS MANAGEMENT: PROFIT ASSURED

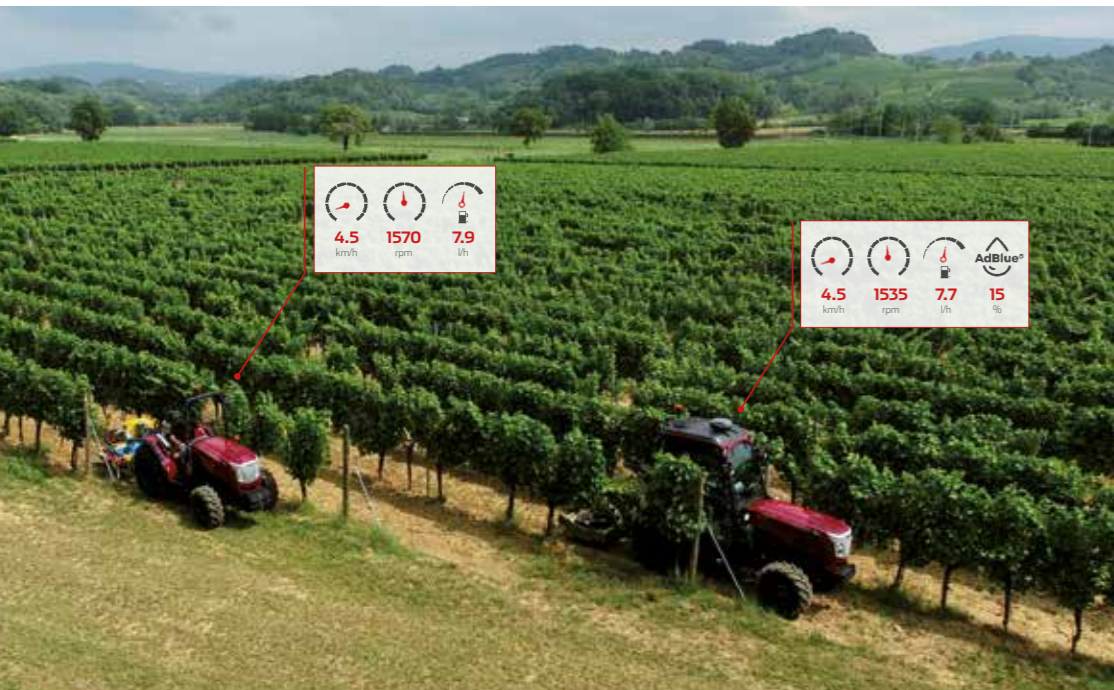

McCormick, a brand globally recognised as synonymous with high performance and cutting-edge technology, equips all its tractors with remote management and diagnostic capabilities. The **McCormick Fleet & Remote Diagnostics Management system** helps farmers make informed data-driven decisions that will reduce their operating costs while increasing the efficiency and productivity of their farms. The system, which can be easily accessed from a computer or a mobile device, allows farmers to remotely monitor the activity of each tractor and analyse the data of their entire fleet of vehicles. This advanced solution is based upon four key elements:

1. Real-time fleet monitoring
2. Data analysis
3. Scheduled maintenance and remote diagnostics
4. Activity history

McCormick is fully committed to addressing the needs of modern agriculture with concrete and effective solutions. The **McCormick Fleet Remote Diagnostics Management system** helps farmers manage their farms more efficiently by favouring the most appropriate choices in order to maintain their tractors in good working order, optimise their work and increase their business profitability.

1. Real-time fleet monitoring: The system displays at any time the exact location of each tractor in a fleet and, using the Geofencing technology, notifies whenever a vehicle enters or exits a specified zone. It also measures the efficiency of each tractor by checking parameters like speed, engine hours and RPMs, fuel and AdBlue levels, average consumptions and work progress.

2. Data analysis: The data coming from the tractors allow the system to measure the productivity of each vehicle in the fleet and the farm's operating profit. These data are essential to monitor and reduce costs, make predictions, organise work plans and take informed decisions.

3. Scheduled maintenance and remote diagnostics: The tractor fleet is managed in a simple and fast manner. In case of failure, our aftersales service intervenes remotely in real time in order to adopt the most appropriate solutions and to improve the tractor's performance, thereby reducing downtime and extending the equipment's life.

4. Activity history: This function delimits the work areas and stores the data of the activities performed. This allows the user to better organise the work, increase efficiency and productivity and maximise profitability.



McCORMICK FARM TECHNOLOGY FOR A MORE PRODUCTIVE FARM

McCormick improves the efficiency of your farming operations. But not only this: **McCormick Farm** connects your tractor to an intelligent and intuitive farm management system. This brings farmers a number of benefits in terms of time saving, work simplification and enhanced performance.

360-degree management solutions for your farm

McCormick Farm supports more than 400 different crops and allows virtually all tasks on the farm to be accomplished, including crop management, tracking and planning of field activities, advice on crop protection and irrigation practices, creation and exchange of prescription maps with monitoring of costs and sustainability, export of documents.

Connected to your McCormick

By connecting your McCormick to the **McCormick Farm** app, you can view performance levels and reports on the farming activities carried out in the fields. In addition, you can display prescription maps, A/B lines, boundaries and obstacles.

Always at your fingertips

Whether in the field or on the farm, McCormick is always at your side, thanks to the **McCormick Farm** app for smartphone and tablet. And if you want to run your business from your computer, you may access the web version synchronised with the mobile devices.

Simple and intuitive

McCormick Farm is designed to be clear and user-friendly. A support chat answers questions about the use of the app.





PRECISION STEERING MANAGEMENT FOR PRECISION PERFORMANCE



Precision farming has been in existence ever since man started to cultivate land. Today, thanks to technological development, precision farming is carried out with cutting-edge tools that improve efficiency and increase productivity. McCormick uses the innovative **PSM (Precision Steering Management)** system, a set of integrated devices for satellite-assisted guidance that can be managed from the tractor cab via an intuitive touch screen, on which the tasks to be performed in the field can be easily imported. Thanks to the precise automated steering control, the tractor only deviates 2 cm from the desired route, eliminating overlaps. This helps operators work with more speed and accuracy and reduces operating costs and environmental impact while raising efficiency and productivity in the field.

ISOBUS & ISOBUS GREEN MAKE YOUR WORK SIMPLE AND EFFICIENT

In 2015, Argo Tractors received the AEF ISObus certification. The **ISObus** system is the standard protocol through which the on-board computer communicates with the tractor and implements. The automatic control of **ISObus**-compatible implements allows variable-rate applications to be delivered through prescription maps generated by McCormick Farm. All **ISObus**-compatible implements are managed via a DSM 12"

touch screen monitor to improve operating efficiency and productivity. McCormick is a leading participant in the innovative **ISObus Green** project. This project allows farmers to retrofit their mechanical implements with the technology so as to connect them to the tractor's **ISObus** system. This solution maximises the efficiency of every implement.

Precision Steering Management & ISObus bring benefits to the field

The **Precision Steering Management** and the **ISObus** system are innovative technologies adopted by McCormick to increase efficiency and productivity while improving comfort and safety:

- › All implement activities are managed with a high level of accuracy, including in automatic mode.
- › Difficult manoeuvres are simplified, thereby reducing operator fatigue.
- › When the driver must attend to driving and simultaneously control the implements, the PSM satellite-based guidance system will allow them to fully concentrate on the task at hand.
- › The satellite guidance system tracks field operations with maximum accuracy.

Thanks to the RTK protocols, the automatic steering allows a deviation of only 2 cm from the set route.

- › Reducing the travelled distance in the field reduces tractor and implement wear and tear and saves fuel.
- › The use of variable-rate applications based on prescription maps generated by the McCormick Farm platform eliminates skips and overlaps, minimizing product waste. Variable-rate technology reduces overuse of water, seed use by 10%, fertilizer use by 16% and herbicide use by up to 60%.
- › Chemical residues are also reduced with significant benefits for the environment.
- › Reports and pre-setting operations are simpler and can be done autonomously without recourse to skilled personnel.

ARGO TRACTORS FLEET ROUTER MANAGEMENT SIMPLIFIES YOUR WORK



The new digital technologies have rapidly multiplied the sources and destinations of data. Today, it is paramount for both small farmers and large agricultural businesses to enable different systems to communicate with each other. For this reason, on March 30, 2023, Argo Tractors has become an **Agrirouter** certified partner with the account *Argo Tractors Fleet Router Management*. **Agrirouter** is a universal data exchange cloud platform that allows the interchange of information between machinery, equipment and software of different manufacturers. **Agrirouter** links different sources and platforms, simplifying the operating processes and ensuring data confidentiality. The operator keeps everything under control with a single system. By connecting the tractor to the implements, including those from different manufacturers, and to the McCormick Farm platform, a simple and efficient integrated management of both machinery and farm is achieved.

MY McCORMICK APP, THE McCORMICK WORLD IN YOUR HAND

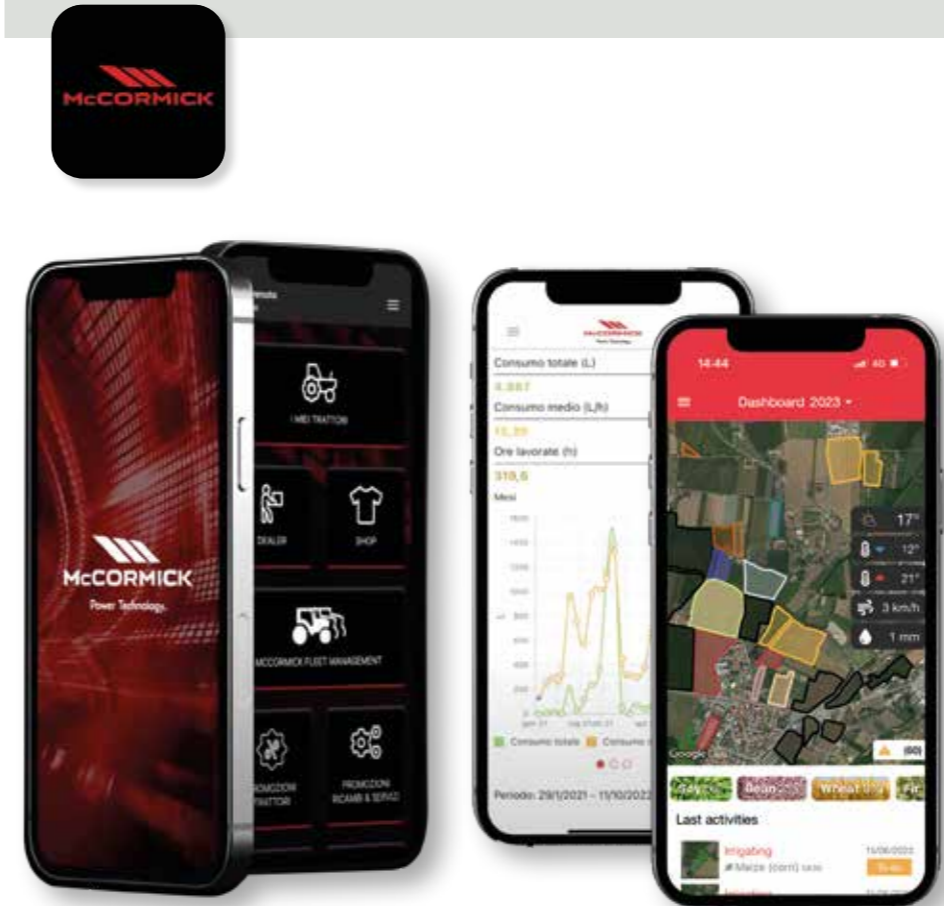

The intuitive **My McCormick** app offers the user a 360-degree immersive experience through our Digital Solutions. The **My McCormick** app gives you easy access to all McCormick digital services, allowing you to stay connected with the company through news, insights, offers and customised information. With **My McCormick** you can:

- > Register your McCormick tractor fleet and access the scheduled maintenance program.
- > Access the McCormick Fleet & Remote Diagnostics Management system.
- > Access the McCormick Farm platform.
- > Stay updated with the very latest news and events from the McCormick world.
- > Stay informed on promotions and offers of tractors, original spare parts and services.
- > Stay updated with new products, promotions and events from the nearest dealer.

McCormick is always at your side. With the **My McCormick** app you have the whole McCormick world at your fingertips, so you stay informed and optimise your work making it more efficient and productive.



QUICK MAINTENANCE TO GET YOU BACK UP AND RUNNING

Designed with versatility and efficiency in mind, the X5 offers a variety of solutions to simplify and speed up maintenance.

1. The tilt-up bonnet opens wide to provide easy access to the engine compartment for maintenance.
2. The oil filler cap is placed in the lower part of the engine, so topping up of engine oil can be done without opening the bonnet.
3. The engine air filter is positioned in such a way as to facilitate cleaning and replacement.

4. The cooling radiators are well spaced and the dust cover can be easily removed to allow for simple and fast cleaning.

5. The fuel tank is conveniently placed to allow quick and convenient filling.
6. The air filters, fitted on the cab roof, are easily accessible for maintenance.
7. The oil level in the transmission can be conveniently checked through the oil filler cap with dipstick placed on tractor rear.



McCORMICK ORIGINAL SPARE PARTS, THE CORNERSTONE OF YOUR PRODUCTIVITY

Although it works hard, your McCormick tractor always looks good as new. With McCormick original parts time seems to have stopped. Our original spare parts are an integral part of our scheduled maintenance and extended warranty program. Developed by the same engineers who design and manufacture the McCormick tractors, genuine McCormick parts are designed and manufactured to the highest quality standards to ensure reliable and safe performance over time. The strong points of McCormick original spare parts are the following:

- **Speed:** Spare parts are always shipped within 24 hours of order receipt.

- **Quality:** Each part comes with a 12-month warranty and is marked with a tamper-proof hologram that certifies the product's quality and originality.
- **Value for Money:** Original McCormick parts are reliable and good value: they improve your tractor performance, maintain high productivity levels and preserve your tractor's value. All McCormick spare parts rely on our extensive design and manufacturing expertise. Because when you choose McCormick, you are choosing quality without compromise.



POWER TECHNOLOGY SINCE 1847

Cyrus Hall McCormick was born in Virginia, United States, in 1809. A keen inventor, he stunned the agricultural world with inventions that mechanised the farm work. In 1831 he invented the first mechanical reaper. In 1847 McCormick established a factory for the production of grain harvesters. In 1866 the company adopted the red colour that still identifies the brand worldwide. In 1871 McCormick manufactured more machines than any other company in the world: 250 reapers per day. The first tractor, the Mogul 8-16, was launched in 1906. In those years, the company opened up factories in Canada, Great Britain, Germany, France and Sweden.

In the following years, the company was purchased and sold several times. In 2000 McCormick was acquired by the Argo Group, which relaunched the brand under the name McCormick Tractors International Limited. Today, McCormick is a world leader in the tractor industry and its name stands for uncompromising technology and innovative design. Thanks to heavy investments in research and development, the new generation of McCormick tractors leads the market for performance and innovation. Farmers look for efficient, reliable and versatile solutions to maximise their productivity – and this is exactly what we are proud to offer our customers.

		X5.100	X5.110	X5.120
ENGINE				
Rated power (97/68/EC - ISO TR 14396)	hp/kW	95.2/70	102/75	114/84
Max power (97/68/EC - ISO TR 14396)	hp/kW	95.2/70	102/75	114/84
Rated engine speed	rpm		2200	
Engine speed at max power	rpm		1900	
Max torque at 1400 rpm	Nm	395	430	460
Torque backup		30%	32%	28%
Manufacturer			FPT	
Engine type			F36	
Stage V / Tier 4 Final exhaust after-treatment system			DOC + SCRof	
Cylinders / Displacement / Valves			4 / 3,6 l / 16V	
Air filter system			dry element air cleaner	
Air intake system			turbo aftercooled	
Fuel injection system			high pressure common rail electronically controlled	
Maintenance interval			500 hours	
Cooling system			matrix radiator package	
Cooling fan			● belt-driven fan - ○ viscous fan	
Engine Memo Switch			●	
CAPACITIES				
Fuel tank	l		135	
AdBlue / DEF tank	l		13	
Cooling system	l		10	
CLUTCH				
Type	l		● mechanical	
TRANSMISSION				
Type			● mechanical - ○ electrohydraulic	
No. of gears - std			● 12 FWD + 12 REV with synchro shuttle (EFFICIENT) - ● 12 FWD + 12 REV with RPS with modulation control (PREMIUM)	
No. of gears - option 1			○ 12 FWD + 12 REV with RPS with modulation control (EFFICIENT) - ○ 24 FWD + 24 REV with Powershift Hi-Lo (PREMIUM)	
No. of gears - option 2			○ 24 FWD +24 REV with Powershift Hi-Lo (EFFICIENT) - ○ 36 FWD +12 REV with XtraShift HML&RPS (PREMIUM) - ○ P4-Drive (PREMIUM)	
Creep			○	
Minimum speed without creeper	km/h		1.5 with Hi-Lo - 1.35 with HML (IR 700mm)	
Minimum speed with creeper	km/h		0.36 with 12+12 / 0.36 with Hi-Lo (IR 700mm) (EFFICIENT) - 0.33 with Hi-Lo / 0.3 with HML (IR 700mm) (PREMIUM)	
Engine speed at 40 km/h	rpm		2038 with HI-Lo & HML (IR 750mm)	
Transmission control			hand lever	
Forward/Reverse shuttle			● Synchro Shuttle - ○ Reverse Power Shuttle (RPS) with modulation control (EFFICIENT) ● Reverse Power Shuttle (RPS) with modulation control (PREMIUM)	
REAR PTO				
Type			● mechanical - ○ electrohydraulic	
Speeds	rpm		● 540 - ○ 540 / 540E - ○ 540 / 1000 (EFFICIENT) - ● 540 / 540E - ○ 540 / 1000 - ○ 540 / 540E / 1000 / 1000E with HML (PREMIUM)	
Ground speed PTO			○	
Engine speed at rated PTO speeds - 540/540E/1000/1000E	rpm		1944 / 1377 / 1935 / 1621	
Rotation - type of spline shaft			clockwise (viewed from tractor rear) ● 1-3/8" PTO shaft with 6 splines - ○ 1-3/8" PTO shaft with 21 splines	
FRONT AND REAR AXLES				
Front rigid axle			● (EFFICIENT-PREMIUM)	
Front suspended axle			○ (PREMIUM)	
Traction type			4WD	
Front differential lock			Hydralock full locking differential	
Rear differential lock			● electrohydraulic	
Rear axle - flanged type			●	
BRAKING SYSTEM				
Front braking system			● automatic 4WD engagement when braking - ○ with front brakes	
Rear braking system			ring piston hydraulic brakes	
Trailer braking system			● dual-line hydraulic brake as per MR - ○ single-line hydraulic brake or CUNA ○ dual-line pneumatic brake*	
Park Lock			○ (only with RPS)	
HYDRAULIC SYSTEM				
Hydraulic pump for rear hitch & remote valves + steering - flow rate			● 62 + 32 l/min (EFFICIENT-PREMIUM) - ○ 82 + 32 l/min (PREMIUM)	
Rear remote valves - type, number			mechanical, 2 - 3 (EFFICIENT) - mechanical up to 3 + electrical 1 (PREMIUM)	

		X5.100	X5.110	X5.120
HYDRAULIC SYSTEM				
Flow divider / Flow selector			○	
Free-flow return			●	
Mid-mounted remote valves - type, number, flow rate			2 mechanical with multifunction joystick - 80 l/min	
Hydraulic oil take out	l		● up to 35	
REAR 3-POINT HITCH				
Rear hitch control			● mechanical - ○ mechanical with ELS (EFFICIENT) - ● electronic (PREMIUM)	
Category - coupler type			II - ○ fixed ball ends - ○ quick-hitch hooks - ○ telescopic lower links	
Max lifting capacity at hitch points	kg		○ 4500 (EFFICIENT) - ● 4500 (PREMIUM) with twin assistor rams	
FRONT 3-POINT HITCH				
Front hitch			○	
Category - coupler type			II - ● quick-hitch hooks	
Max lifting capacity at hitch points	kg		2200	
FRONT PTO				
Type - Speed	rpm		○ electrohydraulic multidisc with modulated engagement - 1000	
Engine speed at PTO rated speed	rpm		1920	
Rotation - type of spline shaft			○ clockwise (viewed from tractor front) - ● 1-3/8" PTO shaft with 6 splines	
CAB				
Total View Slim cab mounted on silent blocks			● (EFFICIENT-PREMIUM)	
McCormick mechanical cab suspension			○ PREMIUM	
In-cab noise level	dB(A)		78 (EFFICIENT) - 76 (PREMIUM)	
Controls & Joystick			○ - SmartPilot Joystick (transmission control, RPS, engine memo switch, de-clutch function,, PTO and rear hitch controls)	
Filtration category			Cat. 2	
Heating / Climate control system			● heat and ventilation - ○ manual climate control	
Opening front windscreen			●	
Mechanical seat			● EFFICIENT	
Comfort air suspension seat			● EFFICIENT - ○ PREMIUM	
Trainer seat			○	
Radio ready			●	
Radio system			○ - radio DAB mp3, with 2 loud speakers, bluetooth, aux-in and integrated microphone	
ROPS version			○	
Work lights - EFFICIENT version			● 4 work lights - 2 on roof front, 2 on roof rear ○ 8 work lights - 2 on roof front, 2 on roof rear, 2 on bonnet, 2 on handles (LED)	
Work lights - PREMIUM version			● 6 work lights - 2 on roof front, 2 on roof rear, 2 on bonnet ○ 8 work lights - 2 on roof front, 2 on roof rear, 2 on bonnet, 2 on handles (LED) ○ 10 LED work lights - 2 on roof front, 4 on roof rear, 2 on bonnet, 2 on handles	
Beacon lights			● left side - ○ left and right side	
ON-BOARD TECHNOLOGY				
Advanced Driving System			○ - ADS+, PSM ready with EazySteer	
Rear ISObus			○	
PSM Precision Steering Management			○ ready kit ○ - EGNOS with ADS+ & X25 8,4" touchscreen and AGS-2 aerial ○ - RTK NTRIP full kit (AT Spare Parts)	
Fleet & Remote Diagnostics Management & McCormick Farm Pro Pack			(on selected markets) ● - 1 year ○ - 3 years ○ - 5 years	
WEIGHTS AND DIMENSIONS				
Wheelbase	mm		2355	
Max height over cab without beacon lights	mm		2623 - measured with tyres 380/70R24 - 480/70R34	
Max height from top of cab to rear axle centre	mm		1873	
Max length with front weights - Track width (min - max)	mm		4460 - (1958 - 2458) - measured with tyres 380/70R24 - 480/70R34	
Steering radius	mm		5300 - measured with tyres 380/70R24 - 480/70R34	
Shipping weight - measured with average specs	kg		4000	
Gross vehicle weight	kg		7000	
Max front and rear tyre size - (Index Radius -IR)	mm		380/70R24 - 480/70R34 (IR 750mm)	
Front weight support / Front tow pin			●	
Front weights	kg		○ 6x36 - ○ 10x36	
Rear weights	kg		○ 2x60 - ○ 4x60	
Key:			● standard ○ option * aftermarket	

		X5.085
ENGINE		
Rated power (97/68/EC - ISO TR 14396)	hp/kW	75 / 56
Max power (97/68/EC - ISO TR 14396)	hp/kW	75 / 56
Rated engine speed	rpm	2200
Engine speed at max power	rpm	1400 to 2200 rpm
Max torque at 1400 rpm	Nm	375
Torque backup		56%
Manufacturer		FPT
Engine type		F34
Stage V / Tier 4 Final exhaust after-treatment system		DOC-DPF
Cylinders / Displacement / Valves		4 / 3.4 l / 8 V
Air filter system		dry air filter
Air intake system		turbo aftercooled
Fuel injection system		electronically-controlled high-pressure common rail system
Maintenance interval		500 hours
Cooling system		matrix radiator package
Cooling fan		● belt-driven fan - ○ *viscous fan
Engine Memo Switch		●
CAPACITIES		
Fuel tank	l	103
CLUTCH		
Type	l	● mechanical
TRANSMISSION		
Type		● mechanical - ○ electrohydraulic
No. of gears - std		● 12FWD + 12REV with synchro shuttle - ○ RPS with modulation control
No. of gears - option 1		○ 24FWD + 24REV with RPS with modulation control & Hi-Lo
No. of gears - option 2		○ 36FWD + 12REV with RPS with modulation control & HML
Creep		○
Minimum speed without creeper	km/h	1.61 with 12FWD + 12REV / 1.35 with Hi-Lo / 1.46 with HML (IR 700mm)
Minimum speed with creeper	km/h	0.36 with 12FWD + 12REV / 0.30 with Hi-Lo / 0.32 with HML (IR 700mm)
Engine speed at 40 km/h	rpm	1901 with Hi-Lo / HML (IR 700mm)
Transmission control		hand lever
REAR PTO		
Type		● mechanical - ○ electrohydraulic
Speeds	rpm	● 540/540E - ○ 540/1000 - ○ 540/540E/1000/1000E - ○ 540
Ground speed PTO		○
Engine speed at rated PTO speeds - 540/540E/1000/1000E	rpm	1944 / 2261 / 1935 / 1621
Rotation - type of spline shaft		clockwise (viewed from tractor rear) ● 1-3/8" PTO shaft with 6 splines - ○ 1-3/8" PTO shaft with 21 splines
FRONT AND REAR AXLES		
Front rigid axle		●
Traction type		4WD
Front differential lock		● limited slip - ○ Hydralock full locking differential
Rear differential lock		● electrohydraulic
BRAKING SYSTEM		
Front braking system		● automatic 4WD engagement when braking
Rear braking system		ramp brakes
Trailer braking system		○ two-line hydraulic brake as per MR - ○ single-line hydraulic brake or CUNA - ○ two-line pneumatic brake*

		X5.085
HYDRAULIC SYSTEM		
Hydraulic pump for rear hitch & remote valves + steering - flow rate		● 56 + 30 l/min
Rear remote valves - type, number		mechanical, 1 - 2 - 3
Flow selector/Flow divider		○
Free-flow return		●
Mid-mounted remote valves - type, number, flow rate		2 mechanical with multifunction joystick - 80 l/min
REAR 3-POINT HITCH		
Rear hitch control		● mechanical - ○ mechanical with ELS - ○ electronic
Category - coupler type		II - ○ fixed ball ends - ○ quick-hitch hooks - ○ telescopic lower links
Ergonomic Lift System (E.L.S.) with hydraulic damping system		○
Max lifting capacity at hitch points	kg	● 3900
FRONT 3-POINT HITCH		
Front hitch		○
Category - coupler type		II - quick-hitch hooks
Max lifting capacity at hitch points	kg	1600
FRONT PTO		
Type - Speed	rpm	○ electrohydraulic multidisc clutch with modulated engagement - 1000
Engine speed at PTO rated speed	rpm	1920
Rotation - type of spline shaft		○ clockwise (viewed from tractor front) - 1-3/8" shaft with 6 splines
CAB		
Total View Slim cab mounted on silent blocks		●
In-cab noise level	dB(A)	77
Filtration category		Cat. 2
Heating / Climate control system		● heating and ventilation - ○ manual climate control
Opening rear windscreen		●
Comfort air suspension seat		○
Trainer seat		○
Radio ready		●
Radio system		○
Halogen work lights		● 2 rear - 2 front
LED work lights		○ 2 front - 4 rear - 2 on door handles
Beacon lights		● left and right side - ○ left side
ON-BOARD TECHNOLOGY		
Speed Socket (ISO 11786)		○
Advanced Driving System		○ - ADS+, PSM ready with EasySteer
PSM Precision Steering Management		○ ready kit ○ - EGNOS with ADS+ & X25 8,4" touch screen and AGS-2 antenna ○ - RTK NTRIP (AT Spare Parts)
Fleet & Remote Diagnostics Management & McCormick Farm Pro Pack		(on selected marks) ● - 1 year ○ - 3 years ○ - 5 years
WEIGHTS AND DIMENSIONS		
Wheelbase	mm	2171
Max height over cab without beacon lights	mm	2485 - measured with tyres 280/85R24 - 420/85R30
Max height from top of cab to rear axle centre	mm	1828
Max length with front weights - Track width (min - max)	mm	4297 - (1643 - 2402) - measured with tyres 280/85R24 - 420/85R30
Steering radius	mm	4700 - measured with tyres 340/85R24 - 420/85R34
Shipping weight - measured with average specs	kg	3700
Gross vehicle weight	kg	5800
Max front and rear tyre size - (Index Radius -IR)	mm	380/70R24 (IR 575mm) - 480/70R34 (IR 750mm)
Front weight support		●
Front weights	kg	○ 6x36 - ○ 8x36
Rear weights	kg	○ 2x60 - ○ 4x60

Key: ● standard ○ option * aftermarket

	X5.100 HC	X5.110 HC
ENGINE		
Rated power (97/68/EC - ISO TR 14396)	hp/kW 95/70	102/75
Max power (97/68/EC - ISO TR 14396)	hp/kW 95/70	102/75
Rated engine speed	rpm 2200	
Engine speed at max power	rpm 1900	
Max torque at 1400 rpm	Nm 395	430
Torque backup	30%	32%
Manufacturer	FPT	
Engine type	F36	
Stage V / Tier 4 Final exhaust after-treatment system	DOC + SCRoF	
Cylinders / Displacement / Valves	4 / 3.6 l / 16V	
Air filter system	dry air filter	
Air intake system	turbo aftercooler	
Fuel injection system	electronically-controlled high-pressure common rail	
Maintenance interval	500 hours	
Cooling system	matrix radiator package	
Cooling fan	● belt-driven fan - ○ viscous fan	
Engine Memo Switch	●	
CAPACITIES		
Fuel tank	l 135	
AdBlue / DEF tank	l 13	
Cooling system	l 10	
CLUTCH		
Type	● mechanical	
TRANSMISSION		
Type	● mechanical - ○ electrohydraulic	
No. of gears - std	● 12 FWD + 12 REV with synchro shuttle - ○ 12 FWD + 12 REV with RPS with modulation control	
No. of gears - option 1	○ 12 FWD + 12 REV with RPS with modulation control	
No. of gears - option 2	○ 24 FWD + 24 REV with Hi-Lo powershift - ○ 24 FWD + 24 REV with Hi-Lo powershift & RPS with modulation control	
Minimum speed without creeper	km/h 1.19 (IR 800mm)	
Minimum speed with creeper	km/h 0.32 with 12+12 / 0.26 with Hi-Lo (IR 800mm)	
Engine speed at 40 km/h	rpm 1960 with Hi-Lo (IR 800mm) 30 ECO	
Transmission control	hand lever	
Forward/Reverse shuttle	● Synchro Shuttle - ○ Reverse Power Shuttle (RPS) with modulation control	
REAR PTO		
Type	● mechanical - ○ electrohydraulic	
Speeds	tr/min ● 540 - ○ 540 / 540E - ○ 540 / 1000	
Ground Speed PTO	○	
Engine speeds at PTO rated speeds	tr/min 1944 / 1377 / 1917	
Rotation - spline shaft type	clockwise (viewed from tractor rear) - ● 1-3/8" PTO shaft with 6 splines - ○ 1-3/8" PTO shaft with 21 splines	
FRONT AND REAR AXLES		
Front rigid axle	●	
Traction type	● 4WD	
Front differential lock	Hydralock full locking differential	
Rear differential lock	● electrohydraulic	
Rear axle - flanged type	●	

	X5.100 HC	X5.110 HC
BRAKING SYSTEM		
Rear braking system	ring piston hydraulic brakes	
Trailer braking system	● dual-line hydraulic brake as MR - ○ single-line hydraulic brake or CUNA	
Park Lock	○ (only with RPS)	
HYDRAULIC SYSTEM		
Hydraulic pump for rear hitch & remote valves + steering - flow rate	● 62 + 32 l/min	
Rear remote valves - type, number	mechanical, 2 - 3	
Flow divider / Flow selector	○	
Free-flow return	●	
Mid-mounted remote valves - type, number, flow rate	2 mechanical with multi-function joystick - 80 l/min	
Hydraulic oil take out	I ● up to 35	
REAR 3-POINT HITCH		
Rear hitch control	● mechanical - ○ mechanical with ELS	
Category - coupler type	II - ● fixed ball ends - ○ quick-hitch hooks - ○ telescopic lower links	
Max lifting capacity at hitch points	kg	● 3900 with twin assistor rams
CAB		
Total View Slim cab mounted on silent blocks	●	
In-cab noise level	dB(A) 78	
Filtration category	Cat. 2	
Heating / Climate control system	● heat and ventilation - ○ manual climate control	
Opening front windscreen	●	
Mechanical seat	●	
Comfort air suspension seat	○	
Trainer seat	○	
Radio ready	●	
Radio system	○ radio DAB mp3, with 2 loud speakers, bluetooth, aux-in and integrated microphone	
Work lights	● 4 work lights - 2 on roof front, 2 on roof rear ○ 8 work lights - 2 on roof front, 2 on roof rear, 2 on bonnet, 2 on handles (LED)	
Beacon lights	● left side - ○ left and right side	
ON-BOARD TECHNOLOGY		
Rear ISObus	○	
PSM Precision Steering Management & rear ISObus - ready	●	
Fleet & Remote Diagnostics Management & McCormick Farm Pro Pack - 1 year	● - on selected markets	
WEIGHTS AND DIMENSIONS		
Wheelbase	mm 2355	
Max height over cab without beacon lights	mm 2870 - measured with tyres 9.5R48 - 9.5R48	
Height from cab roof to rear axle centre	mm 2070	
Max length with front weights - Track width (min - max)	mm 4400 - (1782-2542) - measured with tyres 9.5R48 4WD	
Shipping weight - measured with average specs	kg 4300	
Gross vehicle weight	kg 6000	
Max front and rear tyre size - (Index Radius - IR)	mm 9.5R48 - 9.5R48 (IR 800 mm)	
Front weight support / Front tow pin	●	
Front weights	kg ○ 6x36 - ○ 10x36	
Rear weights	kg ○ 2x60 - ○ 4x60	

Key: ● standard ○ option * aftermarket



Power Technology.

via G. Matteotti, 7 | 42042 Fabbrico [RE] Italia | t. +39.0522.656.111 | f. +39.0522.656.476
webmaster@argotracors.com | www.argotracors.com



graphic design: **gruppo saldatori** | bzzbzz@grupposaldatori.com
All data and illustrations provided in this brochure are for information purposes only and can be changed without notice



6717640A2

X5HC



X5.100 HC - X5.110 HC



McCORMICK

Power Technology.

ENGINE		
Rated power (97/68/EC - ISO TR 14396)	hp/kW	95/70 / 102/75
Max power (97/68/EC - ISO TR 14396)	hp/kW	95/70 / 102/75
Rated engine speed	rpm	2200
Engine speed at max power	rpm	1900
Max torque at 1400 rpm	Nm	395 / 430
Manufacturer		FPT
Stage V / Tier 4 Final exhaust after-treatment system		DOC + SCRoF
Cylinders / Displacement / Valves		4 / 3.6l / 16V
Engine Memo Switch		●
CAPACITIES		
Fuel tank	l	135
TRANSMISSION		
No. of gears - std		● 12 FWD + 12 REV with synchro shuttle - ○ 12 FWD + 12 REV with RPS with modulation control
No. of gears - option 2		○ 24 FWD + 24 REV with Hi-Lo powershift - ○ 24 FWD + 24 REV with Hi-Lo powershift & RPS with modulation control
Creep		~
Minimum speed with creeper	km/h	0.32 with 12+12 / 0.26 with Hi-Lo (IR 800mm)
REAR PTO		
Type		● mechanical - ○ electrohydraulic
Speeds	rpm	● 540 - ○ 540 / 540E - ○ 540 / 1000
Ground speed PTO		○
FRONT AND REAR AXLES		
Front rigid axle		●
Traction type		● 4WD
Front differential lock		Hydralock full locking differential
Rear differential lock		● electrohydraulic
BRAKING SYSTEM		
Front brakes		~
Rear brakes		ring piston hydraulic brakes
Trailer braking system		● dual-line hydraulic brake as per MR - ○ single-line hydraulic brake or CUNA
HYDRAULIC SYSTEM		
Hydraulic pump for hitch & remote valves + steering - flow rate		● 62 + 32 l/min
Rear remote valves - type, min - max		mechanical, 2 - 3
Free-flow return		●
REAR 3-POINT HITCH		
Rear hitch control		● mechanical - ○ mechanical with ELS
Category - coupler type		II - ● fixed ball ends - ○ quick-hitch hooks - ○ telescopic lower links
Max lifting capacity at hitch points	kg	● 3900 with twin assistor rams
CAB		
In-cab noise level		78
Work lights		● 4 work lights - 2 on roof front, 2 on roof rear - ○ 8 work lights - 2 on roof front, 2 on roof rear, 2 on bonnet, 2 on handles (LED)
ON-BOARD TECHNOLOGY		
Rear ISObus connection		○
PSM Precision Steering Management and rear ISObus - ready		●
Fleet & Remote Diagnostics Management and McCormick Farm Pro Pack - 1 year		● - on selected markets
WEIGHTS AND DIMENSIONS		
Max length with front weights - Width (min - max)	mm	4400 - (1782-2542) - measured with tyres 9.5R48 4WD
Shipping weight - measured with average specs	mm	4300

Key: ● standard ○ option ~ not available

All data and illustrations provided in this brochure are for information purposes only and can be changed.